

PRINCO™

*Instrumentation designed
with the user in mind*

Instruction Manual

Princo Models L2631 & L2631R

Continuous Two-Wire Level transmitters with Null-Kote™

Rev 2, June 2013



PRINCO INSTRUMENTS INC., 1020 INDUSTRIAL BLVD., SOUTHAMPTON, PA 18966

PHONE: 800-221-9237 or 215-355-1500

FAX: 215-355-7766

WEB SITE: www.princoinstruments.com

E-Mail: info@princoinstruments.com

Table of Contents

Section 1. Description	1-1
A. General Description	1-1
B. Functional Description	1-1
C. L100 Series Probes Description	1-5
Section 2. Specifications	2-1
A. 1. L2631 & L2631R Continuous Level Transmitter s	2-1
A. 2. L100 Series Probes	2-2
Section 3. Installation	3-1
A. Inspection	3-1
B. Mounting	3-1
C. L2631 Electrical Connections	3-4
D. L2631R Electrical Connections	3-6
E. Intrinsically Safe Installation	3-7
F. Ground Isolation	3-7
Section 4. Adjustments and Operation	4-1
A. Factory Pre-calibration	4-1
B. Cancellation of Coating Effects	4-1
C. Initial Checkout	4-1
D. Calibration Procedure	4-3
E. Diagnostic Indicators and System Troubleshooting	4-5
F. Factory Re-setting of L2631/L2631R Measurement Range	4-8
Section 5. Equipment Service	5-1
Illustrations	
Figure 1-1. L2631 Dimensional Drawing	1-4
Figure 1-2. L2631R Dimensional Drawing	1-4
Figure 1-3. Typical 1" NPT Mounted Probe (Model L101)	1-6
Figure 1-4. Typical 3" Flange Mounted Probe (Model L127)	1-6
Figure 1-5. Typical Dual Flexible Probe (Model L115)	1-6
Figure 3-1. Probe Mounting Locations	3-2
Figure 3-2. L2631 Wiring Connections	3-5
Figure 3-3. L2631 Wiring Diagram with 24 Vdc Power Supply	3-6

Table of Contents

Figure 3-4. L2631R Electrical Connections	3-6
Figure 3-5. Ground Isolation Jumper Location	3-7
Figure 3-6. Ground Isolation	3-8
Figure 4-1. Operational Checkout	4-3
Figure 4-2. Control and Indicator Locations, L2631/L2631R	4-4
Figure 4-3. Ground Continuity and Probe Checks	4-8
Tables	
Table 4-1. Percent of Range to Current Conversion Table	4-2

Section One Description

A. General Description

Princo's Models L2631 and L2631R are multi-featured, high technology, RF impedance sensing, continuous level transmitters. They use the same two wires to receive their operating power and transmit their output signals. Used in conjunction with Princo L100 Series probes, the units monitor level as sensed along the length of the probe and put out a 4 to 20 mA signal which is directly proportional to this level. Null-Kote™ circuitry permits operation in virtually any process material, regardless of its dielectric, conductivity, viscosity or build-up.

The 4 to 20 mA output signal may be transmitted over a distance of 2000 feet to a remote meter, controller, recorder, etc., using almost any unregulated 24 Vdc power supply. Intrinsically safe operation may be achieved through the use of a 24 Vdc regulated power supply and Princo Model S939 Intrinsic Safety Barriers.

The L2631/L2631R is capable of "driving" any current sensing, 4 to 20 mA device with an input impedance of 500 ohms or less.

The highly accurate and stable output of the L2631/L2631R is maintained over the wide ambient temperature ranges commonly found in many outdoors applications.

Self-diagnostic circuits give an immediate indication of many application or installation related problems such as breaches or pinholes in the probe sheath or moisture in the electronic housing. Probe connections are made reliably and automatically when the probe is screwed into the electronic housing.

Other significant features include power supply polarity reversal protection and use of state-of-the-art integrated circuits.

The model L2631, referred to as an "integral unit", is contained within a cast aluminum housing which threads directly onto the L100 Series probe.

The model L2631R is a "remote unit". The electronic controller is contained in a plastic, weatherproof housing mounted in a remote location, such as a cabinet or control room. It is connected to the probe by means of a tri-axial cable and a Model L216 connecting fixture which threads directly onto the probe.

Available accessories which enhance the application of the L2631/L2631R include indicator Models S954, S960 and S975. Refer to Section 1.B.4 for descriptions.

B. Functional Description

1. RF Impedance Theory

The Princo L2631 and L2631R work on the concept of monitoring changes in RF impedance between two sensing elements. The two sensing elements are the "active" element of the probe and the "ground reference", which is either a second probe element or a metal tank wall. The two elements are, effectively, the two plates of a capacitor. The electronic unit produces a 100KHz test signal that is applied across the probe elements and is monitored for changes in amplitude and phase angle.

The primary component of the measurement is the capacitive element (with a -90° phase shift, 100% resistive being the 0° reference point). With no process material touching the probe, the dielectric material between the two probe elements is air, which by definition has a dielectric constant of 1.00. As the process level rises, it displaces air as the dielectric. Since the process

Section One Description

material has a higher dielectric constant than air, capacitance increases, RF impedance decreases and RF current flow increases, in direct proportion to level change.

The secondary component of the measurement is the resistive component. Buildup of a conductive process material coating on the probe produces increased RF current flow. This coating can be defined electronically as a complex resistive-capacitive network. Due to the resistive component, the phase angle of the measurement shifts away from a pure -90° .

The resistive component of the coating is proportional to the capacitive component of the coating and to the increased current flow produced by the coating. Therefore, by monitoring the magnitude of the phase shift away from the -90° point, the signal processing circuitry of the electronics is able to apply a proportional correction to the RF signal, thus subtracting out the error caused by the coating. The corrected RF signal is ultimately rectified and amplified to produce a proportional DC current output.

Many, if not most, process applications are water-based and, therefore, electrically conductive. If the probe elements were both bare metal, the first contact with the process material would short the capacitive plates producing an exceptionally high current flow. Covering one or both of the probe elements with an insulating material such as Teflon or Kynar solves this problem. Now, with no process material touching the probe, capacitance is determined by the combined dielectrics of air and the probe insulation material in series. As the process rises, it displaces the air and effectively shorts the gap between the two probe elements. Now, capacitance is determined by the dielectric of the Teflon or Kynar insulation alone, producing a directly proportional increase in capacitance and RF current flow as level rises. Process linearity is determined solely by the uniformity of the thickness of the insulation material.

Linearity of non-conductive process measurements depends upon uniform, parallel spacing of the probe elements. Probes used for non-conductive applications normally have at least one element insulated. This is to reduce the magnitude of measurement error that would be caused by a small amount of conductive moisture in the process, such as might result from condensation.

2. Signal Processing

The L2631/L2631R is factory set on the appropriate RF capacitive measurement range as required for the specific application, based on a calculated capacitance span. Normally, the range is not re-set in the field. The RF signal, proportional to level and corrected for coating error, is rectified and filtered into a proportional DC voltage. This signal is processed by a series of DC amplifiers and ultimately converted into a proportional DC output current.

Front panel ZERO and SPAN adjustment pots set the span of the DC amplifiers within the pre-set range. The pots are set at the factory relative to calculated zero and span capacitance values for the specific probe and process material application. They are re-adjusted by the user if need requires.

3. Basic Features

- RF Impedance Sensing Technology with Null-Kote™

The L2631/L2631R uses RF impedance technology, proven in tens of thousands of applications. With no moving parts, the measurement depends solely on its modern, electronic circuitry, ensuring years of dependable operation.

- Two-wire Operation

The same two wires provide the 24 Vdc supply and the 4 to 20 mA output signal.

Section One Description

- Coating Cancellation

Null-Kote™ technology allows the cancellation of the build-up on the probe of most process materials. Units are factory set for either Mode A (non-conductive process) or Mode B (conductive process) cancellation. Coating cancellation is effective within specified limits.

- Self Diagnostic Feature

Provides instantaneous, visual indication of the two most common failure modes - shorted and open probe conditions. The A DIAGNOSTIC LED indicates shorted condition; the B DIAGNOSTIC LED indicates open condition.

- Remote Mounting

Model L2631R remote mounting configuration allows mounting of the electronic unit in a cabinet, control room, etc., connected to the probe by a tri-axial cable. Standard cable length is 25 feet; optional lengths available.

- Conformal Coating

An insulating coating (conformal coating) is applied to all circuit boards to protect the circuitry against condensation of moisture.

4. Accessories

- Model S960 Series Digital Process Indicators

LED display digital indicator which accepts any input current range between 0 and 50mA. A 6-digit display can be programmed for nearly all engineering units. Programmable digital filtering enhances stability.

An optional totalizer/ linearizer can be used to totalize or integrate signals up to a maximum display value of 999,999. It features independent scaling and a low signal cutout to suit a variety of signal integration applications. Additionally, nine slopes and offsets can easily be programmed with this option to linearize transducers and non-linear outputs, such as square law devices. Peak/valley (max/min) reading memory, display hold and a signal re-zeroing (tare) function are also included and they are easily recalled and controlled by either the front panel or remote switch. All readings are retained at power-down.

Optional dual relays with parallel solid-state outputs are fully programmable to operate in a wide variety of modes to suit many control or alarm applications.

Refer to Princo Bulletin S-91-2 for specifications.

- Model S975 Digital Loop-Powered Indicator

Small, easy-to-read, 3½ digit, 4-20mA loop powered LED indicator in NEMA 4X rated housing. Can be scaled in percentage of range, 4 to 20 mA, or for one of many engineering units.

Refer to Princo Bulletin L-02-1 for specifications.

Section One Description

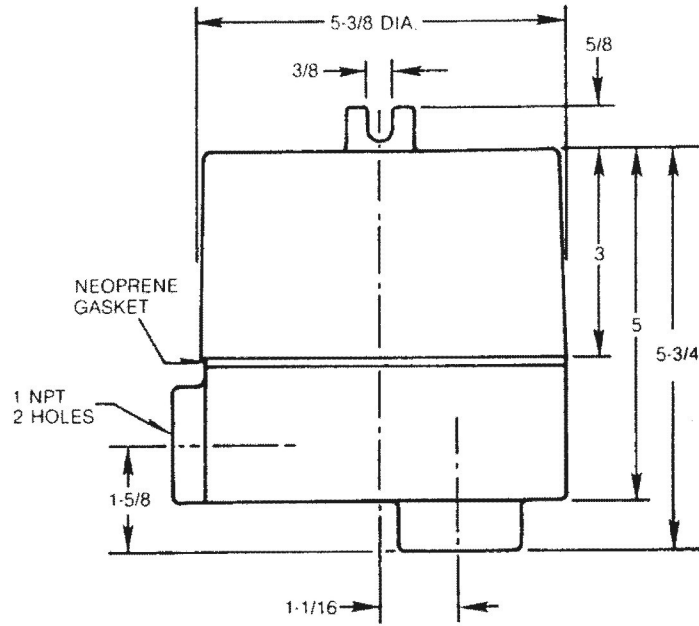

Dimensions in Inches

Figure 1-1
L2631 Dimensional Drawing

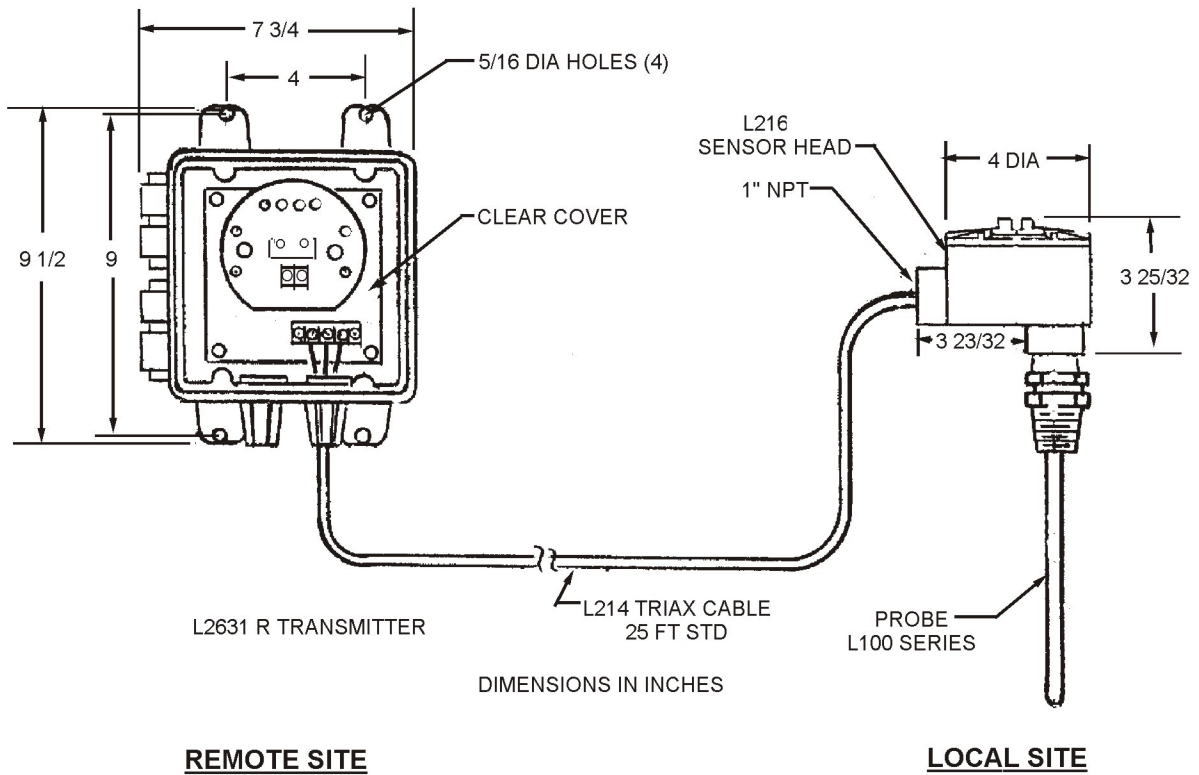

REMOTE SITE

LOCAL SITE

Figure 1-2
L2631R Dimensional Drawing

Section One Description

C. L100 Series Probes

1. General Description

Princo offers a wide variety of probes for use with its continuous transmitters and multi-point controllers. Although the measurement technology remains the same, as outlined in the previous section, different probe designs are suited for different applications.

Electrical, chemical and mechanical considerations affect probe selection. Electrically, a ground reference must be present and the probe must be built to provide proper response.

Chemically, the probe must be compatible with the process material. It must be immune to attack and must offer no chance of contaminating the process.

Mechanically, the probe must be able to withstand the pressure and temperature extremes of the application. In addition, turbulence, consistency, viscosity, abrasion and mounting configuration also play a role in probe selection. A flexible probe is required where probe length exceeds 236 inches or where physical restrictions, such as lack of headroom, prevent installation of a rigid probe.

Single element probes (L101, L104 and L109) are often used in situations where a metal tank wall can provide an adequate ground reference (second element). Non-metallic vessels require dual element probes, as do most non-conductive process applications where probe response and/or linearity would be inadequate using the vessel wall as a ground reference.

Dual element probes are made with either parallel (L115, L116, L127, L128) or concentric (L102, L107) elements. Dual concentric probes provide the best response for low dielectric, low consistency, non-conductive processes as well as minimizing the effects of agitation.

Probe sheathing (Teflon, Kynar, or bare) is chosen with regard to chemical compatibility, as well as probe response and ability to withstand abrasion.

All Princo continuous level probes connect to their respective electronic units by means of a 1" NPT threaded hub. The "ground" contact is made by the threads themselves. The "active" contact is made by the spring-loaded pin which projects from the center of the hub NPT fitting. Refer to Figure 1-3, 1-4 and 1-5. Probes mount to the storage vessel by means of various sizes of flanges, NPT connectors and TRI-CLAMP™ fittings. Refer to Section 2.2 for details.

For detailed listings and specifications for Princo Continuous Level probes, consult Princo Continuous Level Probes Bulletin.

Section One Description

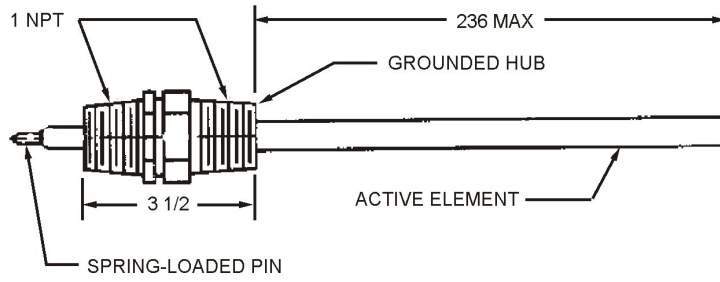

DIMENSIONS IN INCHES

Figure 1-3
Typical 1" NPT Mounted Probe (Model L101)

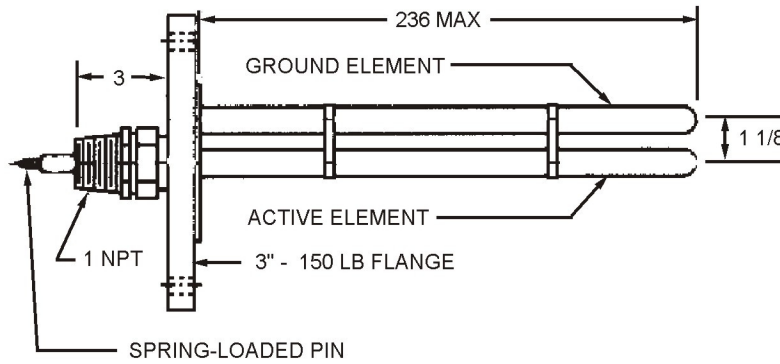

DIMENSIONS IN INCHES

Figure 1-4
Typical 3" Flange Mounted Probe (Model L127)

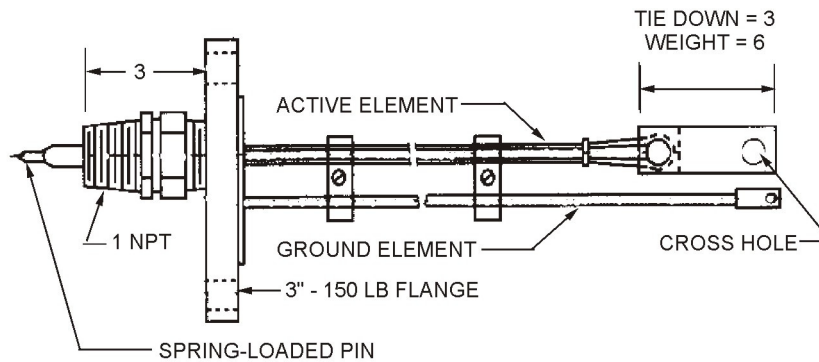

DIMENSIONS IN INCHES

Figure 1-5
Typical Dual Flexible Probe (Model L115)

Section Two Specifications

A. Specifications

1. L2631 & L2631R TWO-WIRE CONTINUOUS LEVEL TRANSMITTERS

- **TYPE**
Continuous, RF Impedance sensing, two-wire, level to current transmitter.
- **SPAN RANGE**
From 0.5 to 100 ft. typical. Shorter spans available with special probes. Consult factory.
- **OUTPUT SIGNAL**
4 to 20 mA_{dc} into:
0 to 300 ohm load at 18 V_{dc}
0 to 500 ohm load at 25 V_{dc}
0 to 700 ohm load at 28 V_{dc}
- **REPEATABILITY/ LINEARITY**
0.5% of span maximum over entire range span.
- **AMBIENT TEMPERATURE RANGE**
-30 to 150 °F (-34 to 66 °C)
- **TEMPERATURE STABILITY**
Maximum error of 0.16% of span per 30°F (17°C) change, or within 1% of span over entire 180°F (100°C) ambient temperature span.
- **PROCESS CONDUCTANCE ALLOWED**
Tolerates process-coating conductance up to 2000 μ S (500 ohms of composite resistance).
- **REMOTE MOUNTING DISTANCE**
Up to 50 feet (cable connected) for all but the shortest span values.
- **POWER REQUIREMENTS**
Single unit without intrinsic safety barrier: Unregulated 20 to 28 V_{dc} at 20 mA.
Single unit with intrinsic safety barrier: Regulated 24 V_{dc} at 20 mA.
Multi units (up to 10) without intrinsic safety barrier: Unregulated 20 to 28 V_{dc} at 200 mA.
Multi units (up to 10) with intrinsic safety barrier: Regulated 24 V_{dc} at 200 mA.
- **ELECTRONIC HOUSING**
L2631: Heavy-duty, cast aluminum.
Explosion-proof for: Class I, Groups C & D; Class II, Groups E, F & G.
Weather proof: NEMA 4.

Section Two Specifications

L2631R Sensor Head (Model L216): Heavy-duty, cast aluminum.

Explosion-proof for: Class I, Div. 1 & 2, Groups C & D; Class II, Div. 1, Groups E, F & G; Class III, Div. 1 & 2.

Weather proof: NEMA 7 CD, 9 EFG.

L2631R Transmitter: Structural foam thermoplastic molded base with hinged, clear polycarbonate cover.

Weather proof: NEMA 1,3, 3S, 4, 4X, 12, 13.

2. L100 SERIES PROBES

- TYPE
Single and dual element continuous, RF impedance level probes.
- DESCRIPTION BY MODEL NUMBER

The below list includes the most commonly used probes. Princo also makes other variations for special applications.

MODEL NO.	ELEMENT CONFIGURATION	TYPE	VESSEL CONNECTION	INSULATION OPTIONS
L101	Single	Rigid	1" NPT	B, KP, KS, TP, TS
L104	Single	Rigid	1", 2", 3" OR 4" TRI-CLAMP™	B, KP, KS, TP, TS
L102	Dual Concentric	Rigid	1½" NPT	B, KP, KS, TP, TS
L107	Dual Concentric	Rigid	1" NPT	B, KS, TP, TS
L109	Single	Flexible	1" NPT	KW, TW
L113	Dual Parallel	Flexible	1" NPT	KW, TW
L115	Dual Parallel	Flexible	3" Flange	KW, TW
L116	Dual Parallel	Flexible	3" Flange	KW, TW
L127	Dual Parallel	Rigid	3" Flange	B, KP, KS, TP, TS
L128	Dual Parallel	Rigid	3" Flange	KP, KS, TP, TS

B = Bare (No insulation)

KP = Kynar® Pipe (60 mil Kynar over carbon steel)

KS = Kynar Sheath (17 mil Kynar over 316 SS rod)

TP = Teflon® Pipe (60 mil PFA Teflon over 316 SS rod)

TS = Teflon Sheath (17 mil Teflon over 316 SS rod)

KW = Kynar Wire (20 mil Kynar over 316 SS wire rope)

TW = Teflon Wire (12 mil Teflon over copper wire)

Section Two Specifications

- PRESSURE / TEMPERATURE RATINGS**

Model Number	Probe Covering	Pressure Rating (PSI) at Temperature Indicated (°F)						
		-300	-40	100	250	300	400	500
L101, L102, L104, L107, L109, L113	Teflon or Bare	1250	1250	1250	550	450	350	0
	Kynar		1000	1000	250	0		
L115, L116, L127, L128	Teflon or Bare	275 ¹	275 ¹	275 ¹	225 ¹	210 ¹	180 ¹	0
	Kynar		275 ¹	275 ¹	225 ¹	0		

NOTES:

1. Rating of Carbon Steel 150 lb. flange. For higher ratings, consult factory.
2. Temperature Limits: Bare or Teflon covered probes: -300°F (-184°C) to 500°F (260°C); Kynar covered probes: -40°F (-40°C) to 300°F (149°C). For temperatures beyond these limits, consult factory.

- SELECTION GUIDE / PHYSICAL DIMENSIONS**

Refer to Princo Continuous Probe Selection Guide

Section Three Installation

A. Inspection

The L2631/L2631R transmitter is supplied with one of the Princo L100 Series level probes. The transmitter and probe are shipped in separate packages.

Carefully remove each package's contents and check each item against the packing list. Inspect each item for shipping damage. In particular, check the spring-loaded connection pin, located on the threaded hub end of the probe (see Figures 1-3, 1-4 and 1-5). This pin provides the necessary electrical connection from the transmitter bottom printed circuit board to the active element of the probe. Make sure this pin is not missing, bent, jammed, or otherwise damaged.

If the probe is sheathed in Teflon or Kynar, then carefully inspect the condition of the sheathing. Make sure the sheathing forms a smooth continuous coverage over the element. Discontinuities in the sheathing material, which breach through to the metal underneath, will render the probe useless in most applications. Report any such damage immediately to the factory.

CAUTION!

Care must be exercised when handling probes that incorporate an insulating sheath. Do not allow the sheathed sensing element to come in contact with a rough or sharp surface, as this may cause a breach in the insulating sheath, and render the probe inoperable.

B. Mounting

1. *Headroom*

Proper specification of a Princo Model L100 Series probe must take into consideration the amount of space available above the storage vessel from which the probe can be lowered into the vessel. This aspect must be considered prior to probe selection and ordering.

In a situation where headroom limits the use of a rigid type probe, a flexible cable type probe can be used. Refer to Figures 1-1 and 1-2 for electronic housing dimensions. A typical cable probe with a 3-inch flange adds about 3½ inches to the height. Additional headroom is needed to remove the lid and access the top panel controls and terminal blocks.

2. *Mounting Location*

Single element probes use the metal tank wall as a ground reference. If they are used in non-conductive applications, they must be mounted close to the sidewall of the tank (6 to 8 inches recommended) and should maintain an equidistant spacing from the sidewall, as the spacing affects measurement linearity. (Princo generally recommends use of factory-made dual element probes for this reason.) When it is impossible to mount the sensing probe close to the sidewall, at least try to favor an off-center mounting. In conductive applications, single element probes may be mounted anywhere relative to metal tank walls. Refer to Figure 3-1.

Dual element probes have a built-in ground reference and generally can be mounted anywhere relative to tank walls, regardless of whether the process is conductive or non-conductive.

Be careful not to mount probes any closer than necessary to such devices as baffles, agitators, heaters, etc. This is especially important when the process is non-conductive. When the process is conductive, it is only necessary to have adequate physical clearance, since there should be little or no adverse electrical effects due to proximity of these devices.

Whether the process is conductive or non-conductive, try to mount the probe in an area where the level is stable and representative. Mounting near an input flow or near splashing might

Section Three Installation

create artificially high level readings. Mounting in a vortex created by a mixer might give an atypically low reading.

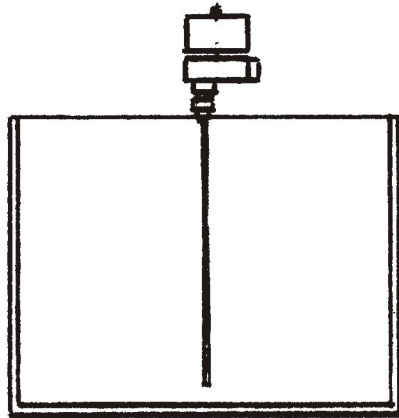

SINGLE ELEMENT PROBE, METAL TANK,
CONDUCTIVE PROCESS.
PROXIMITY TO TANK WALL
UNIMPORTANT.

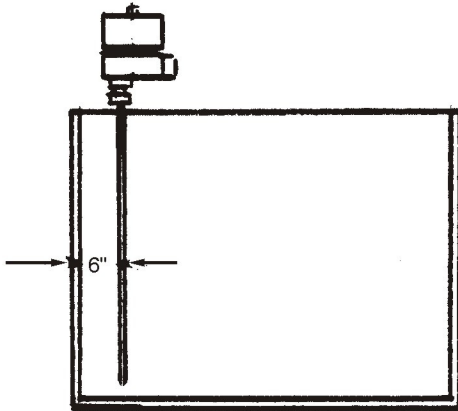

SINGLE ELEMENT PROBE, METAL TANK,
NON-CONDUCTIVE PROCESS.
DISTANCE FROM TANK WALL AFFECTS
RESPONSE. MUST BE PARALLEL TO TANK
WALL FOR LINEAR READINGS.

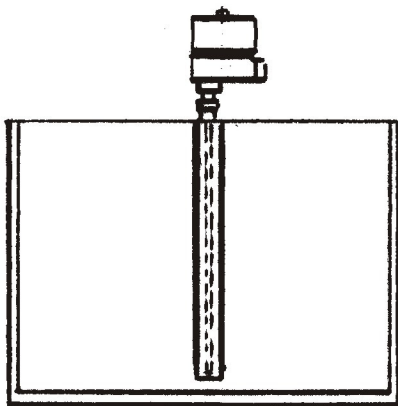

DUAL ELEMENT PROBE (L107),
CONDUCTIVE OR NON-CONDUCTIVE
PROCESS, METALLIC OR NON-METALLIC
TANK.
PROXIMITY TO TANK WALL UNIMPORTANT.

Figure 3-1
Probe Mounting Locations

Section Three Installation

3. *Ground Reference*

Normally, dual element probes (probes with built-in ground references) are used in non-metallic storage vessels. A single element probe may be adapted to the same purpose by supplying a ground reference. The ground reference should be a metal rod, equal in length to the probe. The reference should be mounted parallel to the length of the probe, no greater than 6 to 8 inches from it.

The reference must be electrically connected to the transmitter chassis ground, either directly to the terminal strip ground terminal, or indirectly, by wiring it to the threaded hub of the probe or to the metal housing of the electronic unit. In any case, perform Ground Continuity Check Section 4.E.6.a to ensure that a good ground connection exists.

If the process is non-conductive, non-parallel spacing between the probe and the ground rod will negatively affect the linearity of the level readings. Also, the probe response will decrease as the distance between the two elements increases.

4. *Flange or NPT Mounting*

Princo L100 Series probes are normally mounted by means of a flange (typically two or three inch insertion hole diameter) or an NPT type fitting (standard size is one inch).

a) *Flange Type.* Slip the probe tip into the storage vessel entry port. Lower the probe into the vessel, until the probe flange seats and aligns with the corresponding mating surface on the storage vessel. Fasten the flange to the vessel using the appropriate metal fasteners, gaskets, and sealing compounds, as required by the specific installation.

CAUTION!

Single element flange type probes must be fastened to the storage vessel with metal fasteners, such that electrical continuity exists (zero ohms) between probe flange and metal storage vessel. NPT type probes must be fastened to the storage vessel such that electrical continuity (zero ohms) exists between the probe NPT hub and the metal storage vessel. Do not use any kind of thread lubricant on the NPT threads. If lubrication and/or sealing are required, a small amount of Teflon tape can be used. Refer to Section 4.E.6.a for ground continuity testing.

b) *NPT Type.* Slip the Probe tip into the storage vessel NPT threaded entry port. For probes sheathed with Teflon or Kynar, it is recommended to temporarily line the entry port with cardboard or plastic sheeting to avoid skiving the probe sheathing while guiding the probe through the opening. Lower the probe into the vessel until the probe lower hub NPT fitting seats into the vessel NPT receptacle. Tighten the probe lower hub NPT threads into the storage vessel NPT receptacle using an appropriately sized wrench on the probe hub hex head fitting

5. *Cable Probe Tie-Down*

Princo flexible cable type probes incorporate either a weight or a tie-down at the probe tip, which is designed to keep the sensing element taut as it is immersed in the process material. Refer to Figure 1-5.

If the process material is agitated or is turbulent in any way, it may be necessary to fasten the probe tip to the bottom of the storage vessel. This can be accomplished by using a light cable or nylon rope, looped through the hole in the bottom of the weight or tie-down and, in turn, through a hook fitting in the bottom of the storage tank.

Do not apply excessive downward force to the cable sensing element through the tie-down. It is not necessary and could potentially damage the probe.

Section Three Installation

Also, note that the weight or tie-down is not an electrically active part of the probe. That is, it stands below the zero level of the measured process material. Standard weight length is six inches. Standard tie-down length is three inches.

Teflon spacers on dual element probes (L113, L115, & L116) are designed to keep the dual cables equidistant. Try to maintain even spacing between them, and avoid crossing of cables by excessive twisting, as this will affect accuracy and linearity.

6. *Electronic Housing Mounting*

The electronic chassis of the L2631 is contained within a cast aluminum housing. It is mounted onto the top of the probe by threading the housing's bottom NPT opening onto the probe hub's 1" NPT connector. As with the probe to tank connection, electrical continuity must be maintained through the threaded connection.

NOTE

Do not use any type of thread lubricant on the NPT probe mounting threads or the NPT threads which mount the electronic housing. Application of thread lubricant may cause faulty or improper ground connection. If required, Teflon tape may be used as a thread seal for either threaded connection. If Teflon tape thread sealant is used, the installer should make an electrical continuity check with a hand held ohmmeter. Less than 1 ohm resistance should exist between the storage vessel and the electronic housing. See Section 4.E.6.a.

The spring-loaded pin projecting from the middle of the probe NPT fitting should now be pressing against the underside of the bottom circuit board of the electronic chassis. This may be verified visually through the 1" NPT wiring port on the side of the housing. If the pin is failing to make contact, stretch the spring-loaded pin out further with a pair of pliers. To access the spring-loaded pin, either unthread the housing from the probe hub, or lift the electronic chassis out of the housing after removing the two 8-32 screws which hold it in. Hint: If the spring-loaded pin is properly contacting the circuit board, you will feel the chassis being pushed upward by it as you loosen the two 8-32 screws.

With the L2631R, the procedure is basically the same, except that it is the Model L216 Remote Head which is threaded onto the probe NPT fitting. The electronic chassis is contained in a clear-covered, plastic, housing that is mounted in a location of the customer's choosing and connected by tri-axial cable to the probe via the L216 circuit board.

C. L2631 Electrical Connections

Remove the lid of the L2631 transmitter in preparation for connection of signal/power wires. Before drawing wires into the equipment housing, remove the electronic circuit board chassis. This may be done by removing the two 8-32 chassis mounting screws and lifting the chassis off of the mounting posts and out of the housing. Bring the signal/power wires into the transmitter housing through the 1" NPT wiring port. Leave enough slack in each wire to make connection to the terminal block at the top of the transmitter.

Replace the electronic chassis in the housing, the flat side of the printed circuit boards facing the wiring port. Slide the chassis onto the mounting posts, keeping the wires toward the housing inner wall, so as not to interfere with the chassis. Replace the two 8-32 mounting screws and tighten firmly to ensure proper chassis electrical ground connection.

Section Three Installation

WARNING!

For installation which must be explosion-proof, and/or weatherproof, it is the customer's responsibility to install conduit seals which meet applicable safety standards and/or weatherproof requirements.

Connect two wires (power in/signal out) to the terminal strip as illustrated in Figure 3-2. Make certain wires are installed with correct polarity orientation.

Figure 3-3 outlines a typical overall system wiring using a 24 Vdc power supply.

To achieve ultra-stable operation, apply power and allow a 15-minute warm-up time prior to calibration. Refer to Section 4 for required adjustments.

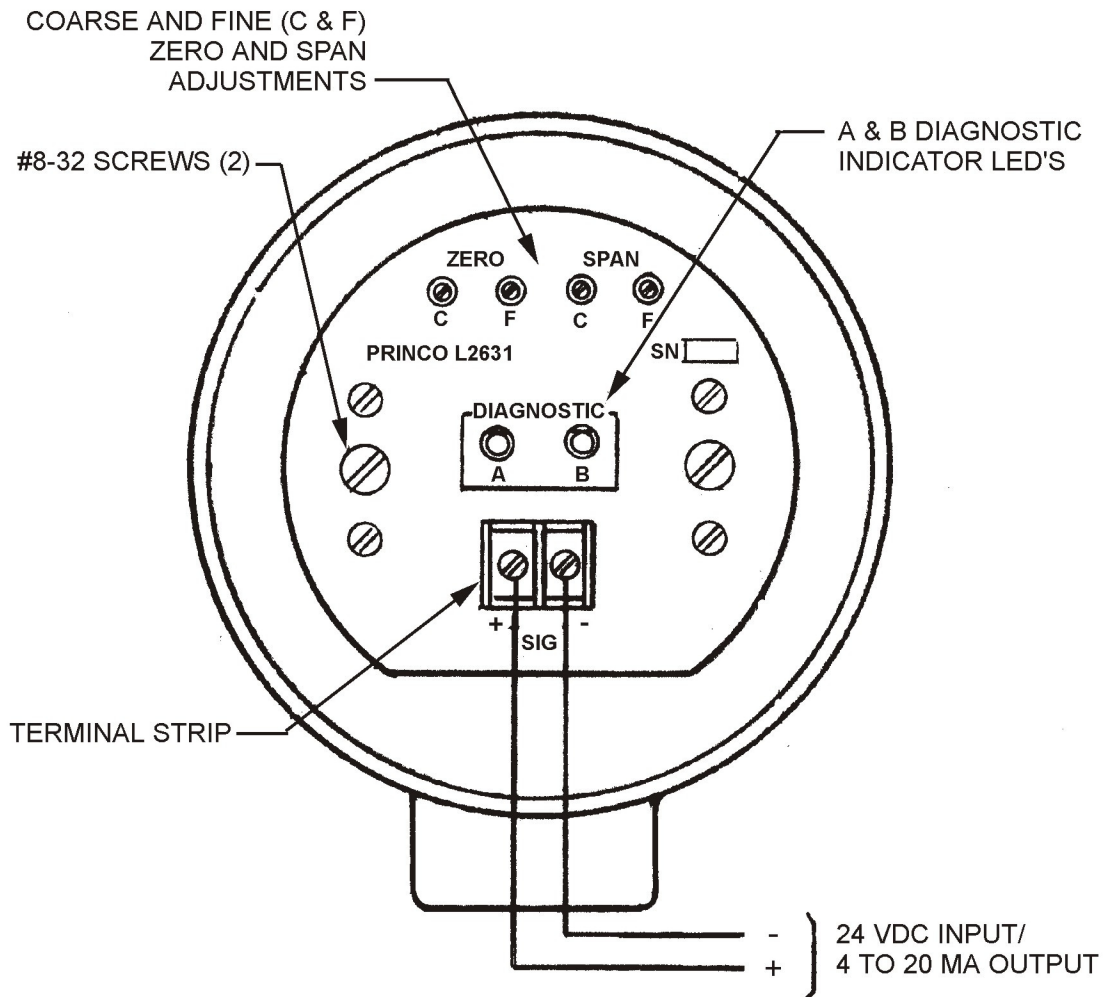

Figure 3-2
L2631 Wiring Connections

Section Three Installation

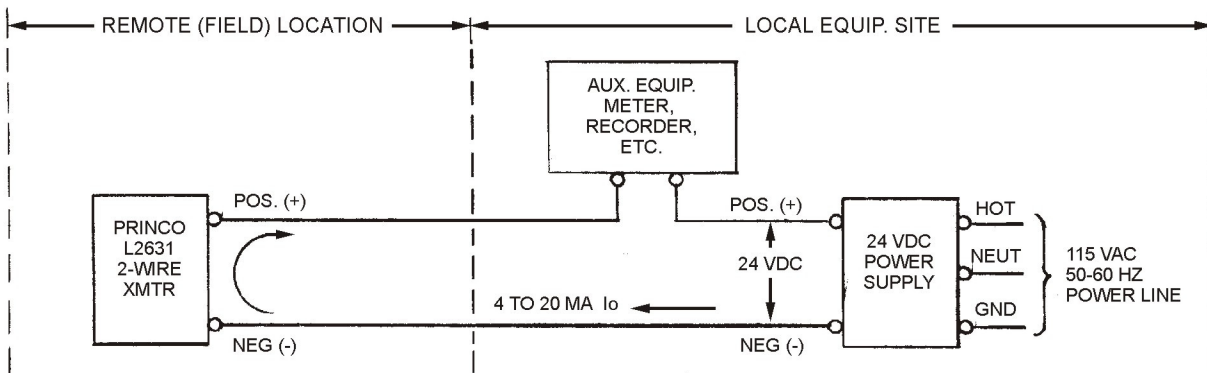

Figure 3-3
L2631 Wiring Diagram with 24 Vdc Power Supply

D. L2631R Electrical Connections

The Model L214 tri-axial cable connects the probe to the L2631R electronic chassis through two three-connection terminal blocks. One is located on the circuit board of the L216 Sensor Head. The other is on the electronic chassis mounting plate inside the plastic housing. Refer to Figure 3-4 for the wiring diagram. Note that the wiring order on both terminal blocks is the same from left to right - Red (guard), Clear (active), and Black (ground). The cable may be drawn through the 1" NPT port on the side of the L216 housing and connected accordingly. Likewise, the other end of the cable can be drawn through one of the two 1/2" NPT wiring ports on the control unit housing and connected to its terminal block. The power/current output wires can be drawn through the other 1/2" wiring port and connected appropriately.

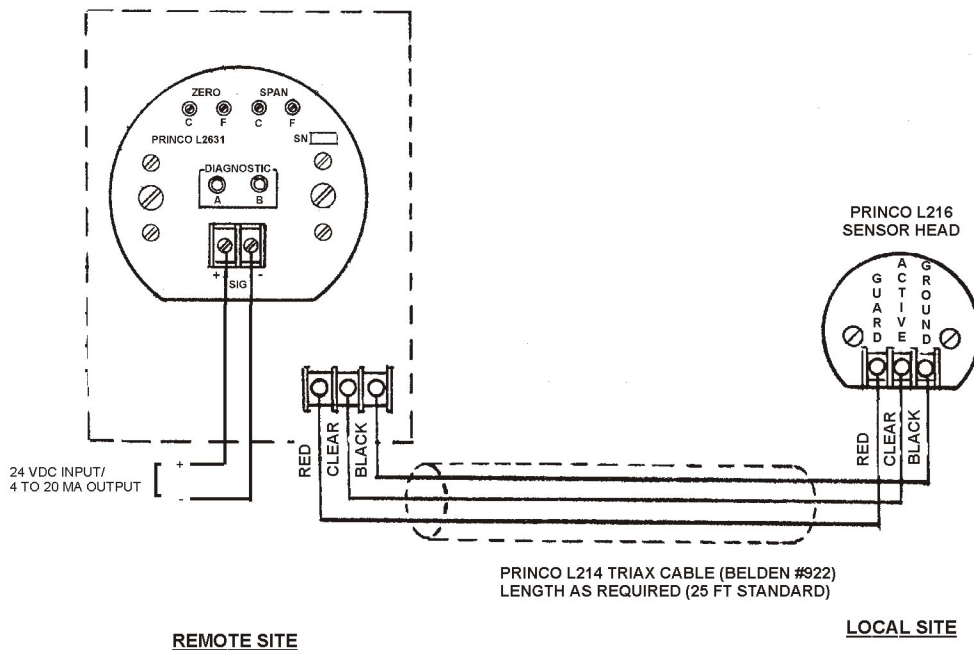

Figure 3-4
L2631R Electrical Connections

Section Three Installation

E. Intrinsically Safe Installation

Making the L2631 safe when operating in a hazardous area requires the use of Intrinsic Safety Barriers which must be installed following a strict installation code. The recommended Intrinsic Safety Barrier is the Princo Model S939 which is manufactured by R. Stahl Inc. (Stahl Type 9002/13-280-110-00).

The installation procedures are defined in Princo's manual for the Model S939 Intrinsic Safety Barriers in outline form, and in the R. Stahl, Inc. Series 9000 manual. Be sure to follow the instructions in both manuals precisely.

F. Ground Isolation

Ground isolation refers to the degree of electrical isolation between an instrument's circuit common (signal minus terminal), and "earth ground" (chassis ground). An instrument without ground isolation has a direct electrical connection between its signal minus terminal and chassis ground.

The L2631 unit is shipped from the factory without ground isolation. If ground isolation is required, it can be easily provided in the field by cutting open the gray ground isolation jumper wire located on the top side of the top printed circuit board as shown in Figure 3-5.

There are several situations where ground isolation is required:

- A ground referenced power supply is used, and auxiliary loop equipment is installed into the negative leg of the signal loop (see Figure 3-6).
- The negative signal leg driving a ground referenced input to a Computer (PLC).
- The metal storage vessel resides at an electrical potential that is elevated above "earth ground".

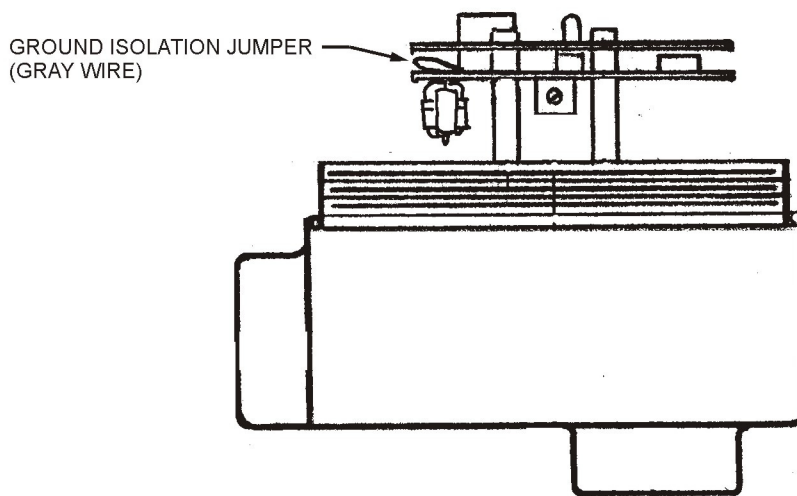

Figure 3-5
Ground Isolation Jumper Location

Section Three Installation

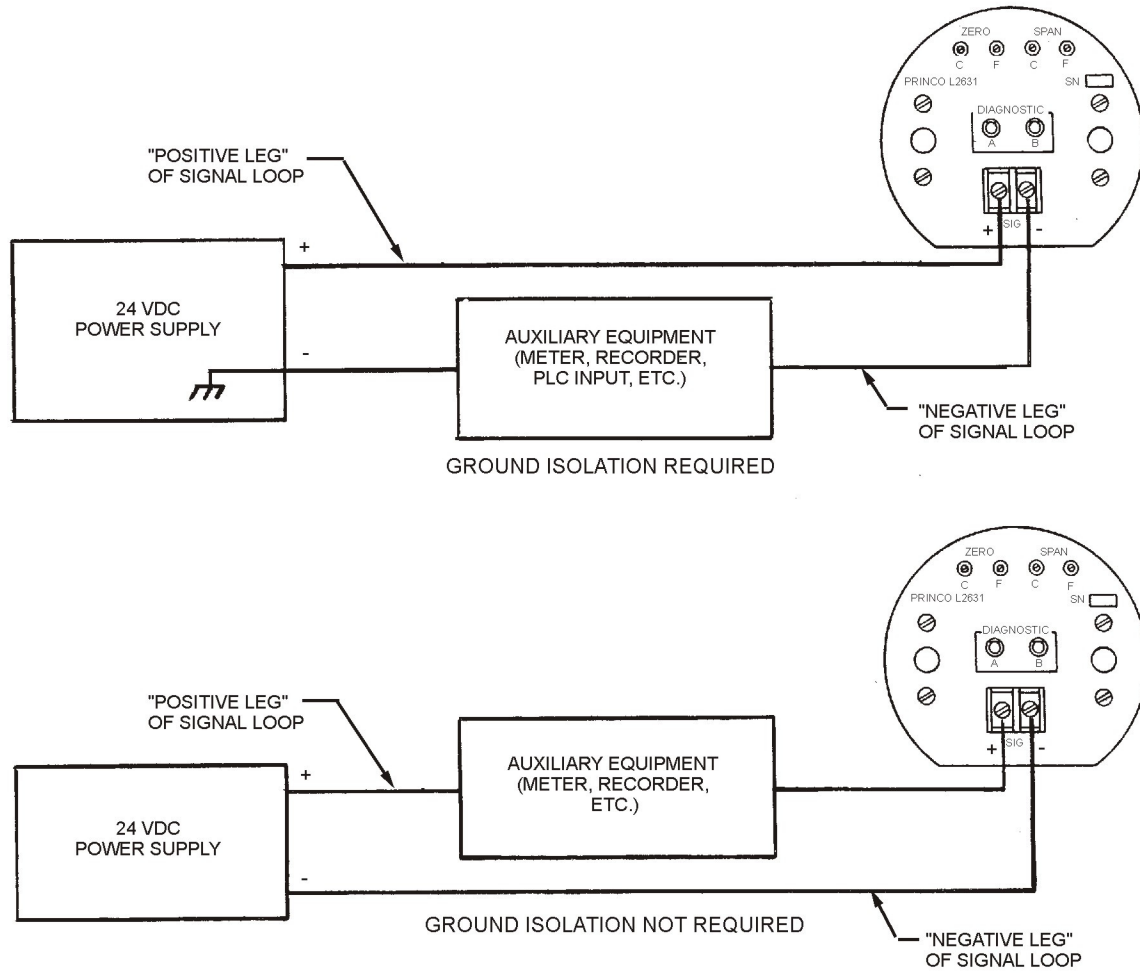

Figure 3-6
Ground Isolation

Section Four Adjustments and Operation

A. Factory Pre-calibration

The Princo models L2631 and 2631R transmitters are supplied pre-calibrated from the factory. The pre-calibration is established from the application information supplied to Princo Instruments by the customer. Information such as probe type, probe mounting geometry, and process material characteristics is used to calculate a “zero capacitance” and a “span capacitance” for the specific application. These capacitance values are then used to perform a bench-top pre-calibration. Note that the 0% (4mA output) and 100% (20mA output) points do not have to coincide with 0 and 100% of probe length, but may, within limitations, be set for points up from the bottom or down from the top of the probe. Consult the factory for specific “zero offset” limitations.

In applications where the L2631/L2631R is required to measure electrically conductive process materials, the pre-calibration is generally very accurate, and no further field calibration is required. In applications measuring electrically insulating process materials, it is more likely that “trimming” of the zero and span adjustments will be required.

B. Cancellation of Coating Effects

When a conventional capacitance type level transmitter is required to measure process materials that are electrically conductive and coating in nature, a significant error in the measurement occurs. The L2631/L2631R incorporates a feature known as Null-Kote™ which negates the effects of these conductive coatings.

The Null-Kote™ feature is actually a sophisticated electronic measurement system that cancels, or “nulls out” the effect of thick or viscous, electrically conductive, process material coatings that may build up on the sensing probe. The unique action of this measurement system automatically cancels the probe coating as the coating increases or decreases in magnitude.

If the process is coating in nature, then, to obtain the highest degree of accuracy possible, pre-coat the sensing probe with the process liquid prior to installation and field calibration.

If the L2631 equipment is transferred from the original application to an alternate one, and significant measurement error is noted, consult the factory.

C. Initial Checkout

1. Install the L2631 or L2631R per the information presented in Section 3 of this manual.
2. Apply power to the unit and allow a 15-minute warm-up time before performing the operational checkout of the equipment.
3. The “A” and “B” LED Diagnostic Indicators, located on the top panel of the L2631/L2631R chassis (see Figure 4-2), should be in the OFF (not illuminated) state. Refer to section 4.E for a functional description of these LED indicators.
4. Check the operation of the L2631/L2631R by verifying the process variable output as follows:
 - a) Connect a calibrated 20-milliamp dc ammeter in the signal loop as shown in Figure 4-1. No other devices are connected into the loop - just the power supply, dc current meter, and transmitter.
 - b) Move the process material level to several positions within the storage vessel (preferably as far apart as possible, but within the known calibrated range of the L2631/L2631R). At each

Section Four Adjustments and Operation

level position, use a dipstick or sight glass to measure and record the actual level from the bottom of the storage vessel. Read and record the corresponding output current for each dipstick level position. Convert the actual level, from each dipstick reading, into a percentage of the calibrated L2631/L2631R span. This number is known as “Percent Level” or “Percent Range”.

NOTE

In order to make this calculation, the 4 mA level position, and the 20 mA level position, must be known relative to the storage vessel bottom.

- c) Table 4-1 below may be used to determine if the output current is within acceptable accuracy limits. The following equations may also be useful in making comparisons:

$$\text{Current Output} = [(\text{Measured Level} - \text{Zero Level}) / \text{Span}] \times 16\text{mA} + 4\text{mA}$$

$$\% \text{Level} = (\text{Current Output} - 4\text{mA}) / 16\text{mA} \times 100\%$$

If the accuracy is unacceptable, then perform the field calibration procedure as per Section 4.D.

Actual Level (from bottom of vessel) (inches)	% Level (% Range)	Transmitter Output Current (Process Variable Output) (milliamps)
Application Specific	0	4.00
"	5	4.80
"	10	5.60
"	15	6.40
"	20	7.20
"	25	8.00
"	30	8.80
"	35	9.60
"	40	10.40
"	45	11.20
"	50	12.00
"	55	12.80
"	60	13.60
"	65	14.40
"	70	15.20
"	75	16.00
"	80	16.80
"	85	17.60
"	90	18.40
"	95	19.20
"	100	20.00

Table 4-1
Percent of Range to Current Conversion Table

Section Four Adjustments and Operation

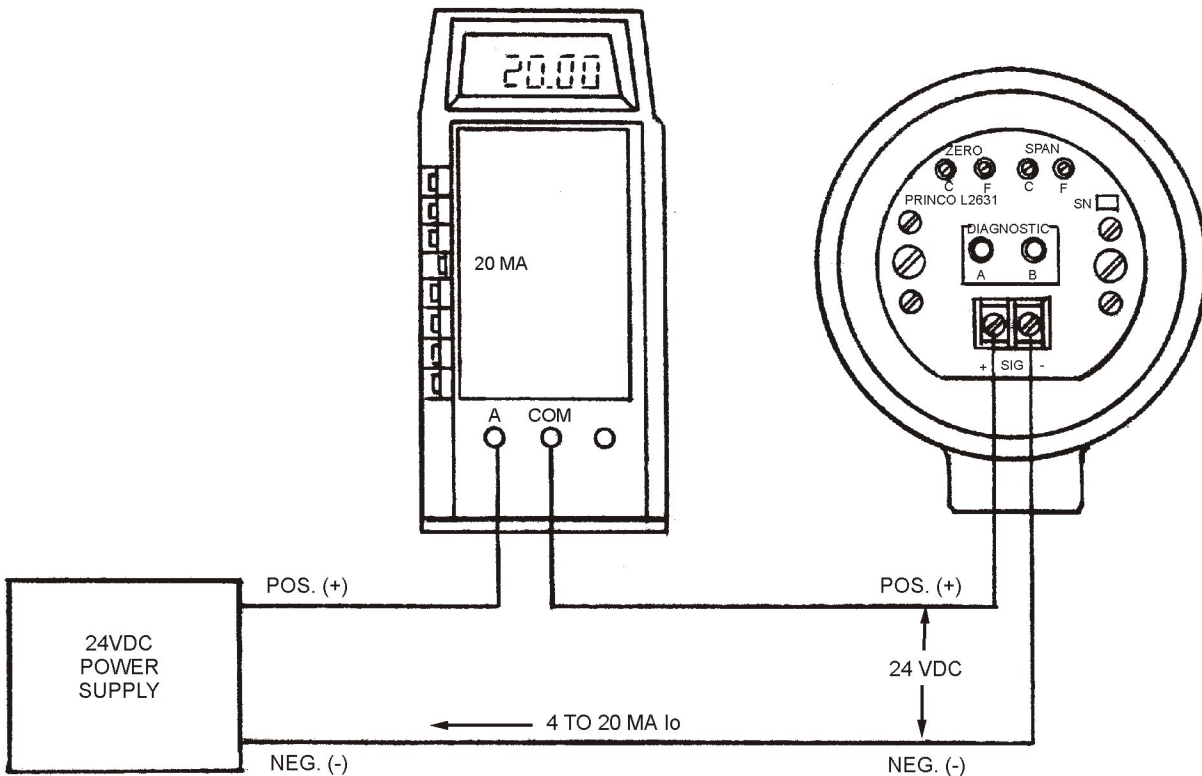

Figure 4-1
Operational Checkout

D. Calibration Procedure

If it is determined that the pre-calibrated L2631/L2631R is not within acceptable accuracy limits, then the unit requires a complete field calibration. Refer to Figure 4-2 for adjustment potentiometers (pots) and indicators locations. Proceed as follows:

1. Pre-set the Coarse (C) SPAN pot to full clockwise rotation. Pre-set the other three pots to half clockwise position (12 o'clock position).
2. Connect a DC ammeter in series with the positive side of the two-wire line at the location of the L2631 or back at the power supply location (Refer to Figure 4-1)

NOTE

Optimum calibration accuracy is obtained by pre-coating the probe with the process material **and** then performing the Zero and Span adjustments with the tank level at the actual zero and span points **and** with the probe mounted in its permanent position within the tank. The ALTERNATE METHODS listed in steps 5 and 6 below will compromise the accuracy to a greater or lesser extent, depending upon variables in the specific application. The user must determine whether the accuracy obtained is within acceptable limits.

3. Raise or lower the process material in the storage vessel to the desired 0% of span point (4 mA point). Usually this is the bottom of the storage vessel or the bottom tip of the probe.

Section Four Adjustments and Operation

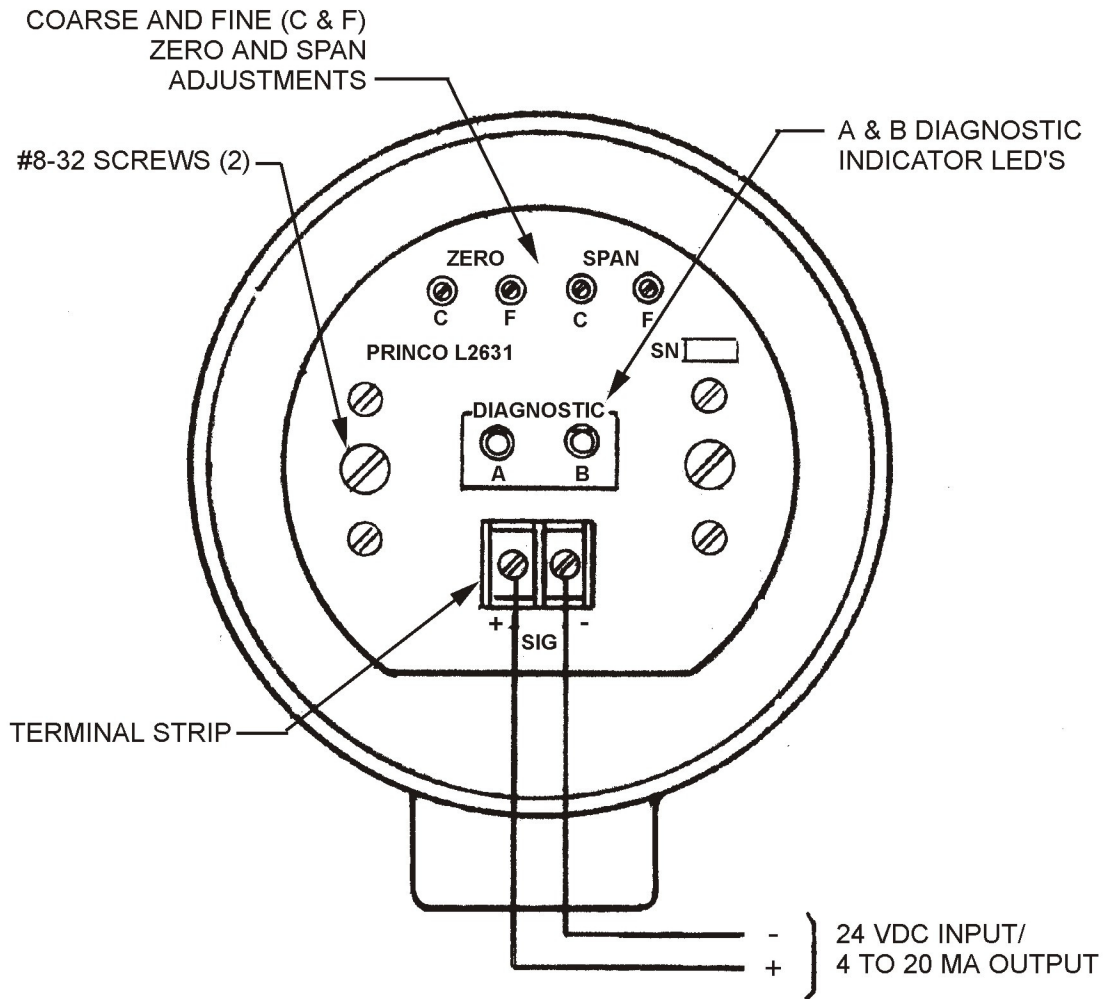

Figure 4-2
Control and Indicator Locations, L2631/L2631R

4. Adjust the Coarse (C) ZERO pot for approximately 4 milliamps on the meter. Adjust the Fine (F) ZERO pot for exactly 4.00 milliamps.

ALTERNATE METHOD: If the storage tank is too full and may not be emptied to the level noted above, an **approximate zero adjustment** may be established as follows. It should be noted that this procedure is not acceptable for single element type probes in an electrically non-conducting process material:

Lift the probe, with housing attached, vertically out of its mounting hole to the point where the process material resides at the desired 0% point (4 mA point) on the probe.

Again, this is usually the bottom most point, or bottom tip of the probe. Do not touch the probe itself during this procedure - only the housing. Make sure that the electronics housing is connected to the metal storage tank with an inter-connecting wire. This is not required in

Section Four Adjustments and Operation

tanks where dual type probes are used. Do not allow probe elements to directly contact a metal tank, metal stand pipe, hands, etc. while making the adjustment.

With the probe stabilized in this position, make the ZERO adjustments as noted above. Replace the housing and probe.

5. Raise the process material level to the desired 100% point.
6. Adjust the Coarse (C) SPAN pot for approximately 20 milliamps on the meter. Adjust the Fine (F) SPAN pot for exactly 20.00 milliamps.

ALTERNATE METHOD: If the storage tank is too empty, and cannot be filled to the level noted above, an **approximate span adjustment** may be established as follows. It should be noted that this procedure is not acceptable for single element type probes in an electrically non-conducting process material:

Fill the storage tank to a more practical level point. This point should not be below 60% of the desired span. Adjust the (C) & (F) SPAN pots to produce a current on the meter equivalent to this level point (expressed as a percentage of the desired span – see Table 4-1 above). When the tank fills completely, the meter should read close to 20 milliamps, or 100%. Trim adjustment again, if required.

NOTE

The SPAN adjustments **do not interact** with the ZERO adjustments, but the ZERO adjustments **do interact** with the SPAN adjustments. Therefore, once the ZERO has been properly set, the SPAN may be reset without shifting the ZERO point. Resetting the ZERO point, however, will shift the SPAN set point.

7. Adjustments are now complete. Remove current meter from the signal loop, and replace the loop back to the original configuration. Screw gasketed lid of equipment on electronic housing until it is firmly seated.

E. Diagnostic Indicators and System Troubleshooting

The System Troubleshooting section below includes problems indicated by the condition of the A and B DIAGNOSTIC indicators as well as problems for which the condition of the indicator lights remains normal. A and B DIAGNOSTIC indicators are in the form of two red LED's on the top panel of the L2631/L2631R. Also below are procedures for checking ground continuity, for testing a probe for breached sheathing and for checking probe response.

1. DIAGNOSTIC A Indicator lit ("shorted" probe indication)

- Breach or break, as small as a pinhole, in sensing probe insulating sheath material. Refer to section 4.E.6.b. and 4.E.6.c., Breached Probe Checks. Consult factory regarding repair.
- Water or foreign liquid collected in probe port of electronic housing. Check wiring port conduit seal and dry housing.
- Conductive film or foreign material bridging probe hub at or near spring loaded connection pin. Clean and check source of problem.

2. DIAGNOSTIC B Indicator lit ("open" probe indication)

- Spring-loaded pin which projects from the top of the probe hub is not contacting the bottom of the printed circuit board. Pin may be safely stretched out with a pair of pliers. Replacement pins available from the factory.
- Probe element shifted, etc. Check for physical damage.

Section Four Adjustments and Operation

- Very loose connection of probe's NPT hub in entry port of electronic housing. Tighten as required. Check ground continuity per Section 4.E.6.a.
- 3. *DIAGNOSTIC A and/or B Indicators Blinking***
 - Intermittent connection of probe's spring-loaded pin. Check spring tension. Stretch out pin with a pair of pliers, if necessary.
 - Intermittently loose connection of probe's NPT hub in entry port of electronic housing. Tighten as required.
- 5. *DIAGNOSTIC A and B indicators not lit***
 - a) Poor Linearity:** Current output goes up and down relative to level change, but accuracy or linearity is unacceptable.
 - Perform Section Four D. Calibration Procedure with probe coated with process material.
 - b) Not Enough Adjustment Range:** ZERO and SPAN adjustment pots do not have enough range to produce full 4 to 20 mA output over level span.
 - Princo level units are factory set for a specific capacitance range based on customer's Application Data Sheet. If more than one unit was ordered, be sure that the correct unit is being used with the application. Units are normally labeled as to the probe or process application with which they are to be used. If problem is not resolved, consult the factory.
 - c) Current output drifts:** After performing calibration procedure, current output drifts over a period of hours or days.
 - Verify that there has not been a change in the conductivity or dielectric constant of the process material. RF impedance technology, by nature, responds to changes in dielectrics. Changes in the nature of the process material may produce different outputs.
 - Significant temperature changes may change the dielectric constant of the process material and also of the probe insulation material, Kynar having a much greater change than Teflon. If output drift correlates with temperature change, consult the factory.
 - Probe Response Check, Section 4.E.6.d below, may be used to help isolate problem.
 - d) Current output erratic:** After performing calibration procedure, current output jumps unpredictably.
 - Check ground continuity per Section 4.E.6.a. (Bad grounds may or may not cause the "B" indicator to light.)
 - Verify that probe is not exposed to splashing or turbulent conditions within the storage vessel.
 - Probe Response Check, Section 4.E.6.d below, may be used to help isolate problem.
 - e) No Output Control:** ZERO and SPAN adjustment pots will not control current output.
 - A constant output current usually indicates a problem with the electronic chassis. First, break the contact between the electronic chassis and the probe, either by unthreading the housing from the probe or by lifting the electronic chassis from its housing. If moving the ZERO and SPAN pots through their extremes produces no change in output current, return the electronic chassis to the factory for repair or replacement. If current control has been restored, perform Breached Probe Check, Section 4.E.6.e. or 4.E.6.f. below.

Section Four Adjustments and Operation

- f) **Measuring Device Loads Down Output:** Unit puts out correct current into a handheld ammeter or calibrator, but output is incorrect when measured by a PLC or other measuring device.
- Input impedance of measuring device must not exceed 500 ohms.
 - A ground loop may be present due to circuitry within the measuring device. Check circuit diagram of measuring device. Refer to Section 3.G. Ground Isolation for instructions on how to isolate the negative current output from the L2631/L2631R chassis ground.
- 6. Ground Continuity and Probe Checks (Refer to Figure 4-3 below):**
- a) **Ground Continuity Check:** With unit power off, using an ohmmeter on the lowest range, measuring between any of the following points should yield less than one ohm:
- 1) Point A (posts) to point B (electronic housing).
 - 2) Point B to point C (probe hub, threads).
 - 3) Point C to point D (except in non-metallic tank).
 - 4) When electronic chassis is installed in housing, the chassis should have continuity to points A, B, and C through the two 8-32 retaining screws which fasten it to posts (A).
- b) **Breached Probe Check:** Conductive liquids only with **bare ground reference** contacting process:
- 1) Raise conductive liquid to highest point on probe.
 - 2) Using an ohmmeter on its highest range (20 megohms), connect meter probes to spring-loaded pin (point E) and hub of probe (point C), respectively.
 - 3) An over-range meter indication indicates the probe sheathing is good. A resistance reading (for example, 1.25 megohms) can mean that sheathing is breached, or there is a short in the probe hub, or moisture in the bottom of the housing.
- c) **Breached Probe Check:** Conductive liquids only with **insulated ground reference** - L128 & L116 probes, lined tank, etc:
- 1) Raise conductive liquid to highest point on probe.
 - 2) Insert a bare metal wire or rod into the process material, depth of insertion not important.
 - 3) Using an ohmmeter on its highest range (20 megohms), connect meter probes to spring-loaded pin (point E) and the metal wire or rod, respectively.
 - 4) An over-range meter indication indicates the probe sheathing is good. A resistance reading (for example, 1.25 megohms) can mean that sheathing is breached, or there is a short in the probe hub, or moisture in the bottom of the housing.
 - 5) Repeat steps 3 & 4, this time with meter probes between the hub of the probe (point C) and the metal wire or rod.
- d) **Probe Response Check:** If the L2631/L2631R output signal readings are erratic or non-linear, and if there is no indication of a poor ground or a breach in the Probe per a, b and c above, the below check can be performed to help isolate the problem.
- 1) Remove power and remove the electronic unit from the probe, either by screwing the electronic housing off of the probe, or by removing the two 8-32 screws and lifting the electronic chassis out of the housing.

Section Four Adjustments and Operation

- 2) Connect a hand-held capacitance meter between points E (spring-loaded pin) and C (probe ground) per Figure 4-3. Capacitance readings should be stable. Changes in capacitance should be linear and directly proportional to changes in level. The approximate capacitance span for a given application may be obtained by consulting the factory.
- 3) If the readings are not stable and linear, the problem is coming from the probe or is associated with the process material or the tank configuration, piping, etc. If the readings are stable and linear, the problem is in the electronic chassis, wiring, readout device, etc. (Be sure to isolate the electronic chassis from all other devices before assuming that the problem is in the chassis.)

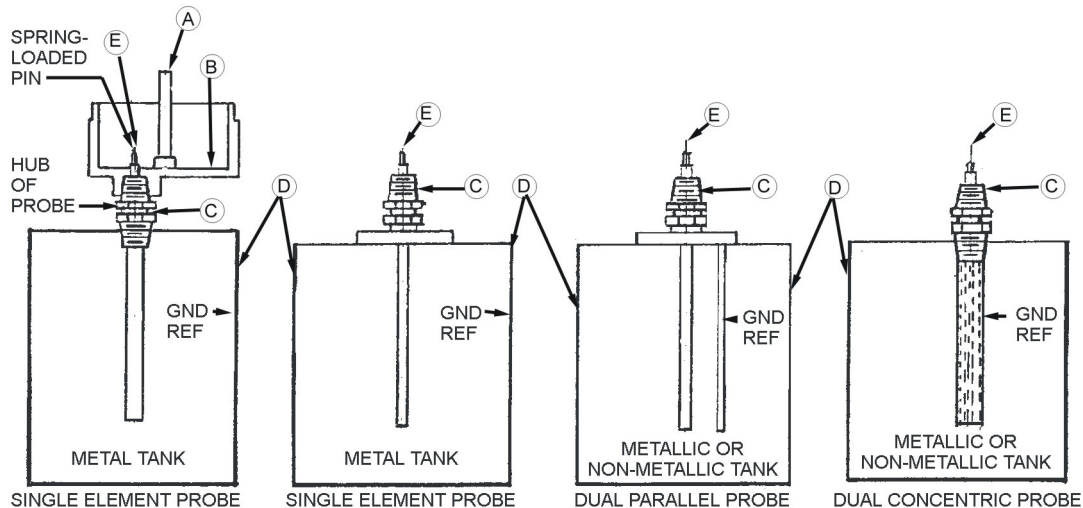

Figure 4-3
Ground Continuity and Probe Checks

F. Field Re-setting of L2631/L2631R Measurement Range

Models L2631 and L2631R are factory-set on a specific capacitance measurement range for the specific probe and process application. The range seldom needs to be reset in the field. Switching the electronic controller for use with another probe or process application may, in some cases, require resetting the range. Consult the factory for the best range setting for the new application.

The range switch is the four-switch DIP switch located on the middle circuit board of the controller chassis. The on position of the switches is up (away from flat edge of circuit board). The off position is down. The switches, from left to right, are 1, 2, 3 and 4 corresponding to ranges 1, 2, 3, and 4. To set a particular range on, push its switch up (on) and all other switches down (off).

Note that many applications will work satisfactorily on more than one range. Also, for optimum performance, some range changes may require circuit board modifications best performed by the factory.

Section Five Equipment Service

A. Getting Help

If your Princo equipment is not functioning properly, and attempts to solve the problem have failed, contact the closest Princo sales representative in your area, or call the factory direct and ask for service assistance. The factory telephone number is 1-800-221-9237.

To assist us in providing an efficient solution to the particular problem, please have the following information available when you call:

1. Instrument Model Number
2. Probe Model Number
3. Purchase Order Number
4. Date of Purchase Order
5. Process Material Being Monitored
6. Detailed Description of the Problem

If your equipment problem cannot be resolved over the phone, then it may be necessary to return the equipment for checkout/repair.

Do not return equipment without first contacting the factory for a Return Material Authorization number (RMA #).

Any equipment which is returned MUST include the following information in addition to the list above.

7. RMA Number
8. Person to contact at your Company
9. Return (Ship to) Address

Princo level instruments are covered by a 10-year limited warranty. You will not be charged if it is determined that the problem is covered under warranty. Please return your equipment with freight charges prepaid. If repair is covered under warranty, Princo will pay return freight charges.

If telephone assistance or equipment return is not a practical solution to the problem, then it may be necessary for field assistance. Trained field servicemen are available from the factory on a time/expense basis to assist in these instances.

B. Warranty Statement

All Princo level control instruments are backed by a 10-year warranty. Princo will repair or replace, at our option, any instrument that fails under normal use for up to 10 years after purchase.